

Wind for Schools 2016

Jerry Hudgins
Wind Applications Center Director
University of Nebraska

Nebraska WAC Faculty

- Dr. Jerry Hudgins, WAC Director
 - Dr. Dean Patterson, electric machine and power converter designs.



- Dr. Sohrab Asgarpour, specializing in power system reliability and distributed generation systems.

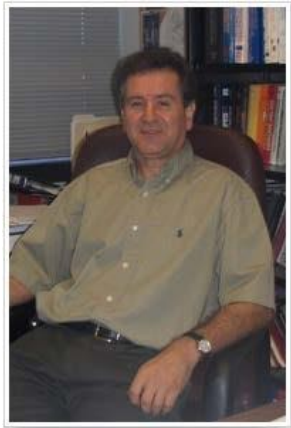

- Dr. Wei Qiao, specializing in distributed generation systems, wind turbine monitoring, and grid connection issues.



Nebraska WAC Activities

- Wind resource and energy usage analysis
- Siting and permitting help for Schools
- Overseeing the installation of the power and the data acquisition system
- Performance data analysis
- Teacher training for Wind Energy Science and Systems
- Curriculum samples for teachers
- University Activities
 - Student projects
 - Research
 - Created new technical symposium related to wind energy electrical systems that has since been adopted by the major electrical engineering professional organization, IEEE

Wind for Schools Participant Map

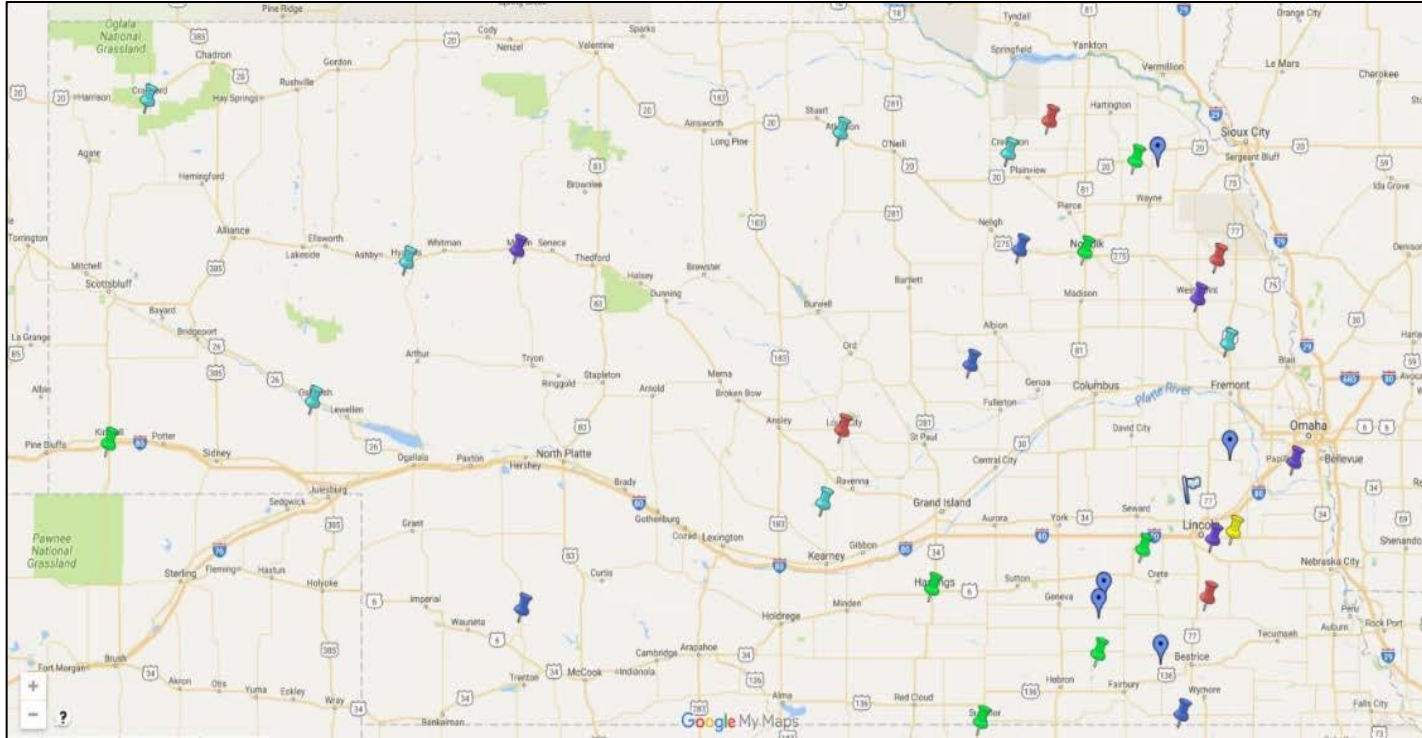

□ 24 Nebraska Schools participating

Bancroft Rosalie Public
Bloomfield Community
Crawford Public
Creighton Community Public
Diller-Odell Public
Elkhorn Valley District
Garden-County Public
Hastings Public
Hayes Center Public
Hyannis Public
Kimball Public
Laurel-Concord Public
Logan View Public
Loup City Public
Meridian Public
Mullen High
Norfolk Public
Norris Public
Papillion-La Vista South Public
Pleasanton Public
Riverside Public
Superior Public
West Holt High
West Point Public

Estimate that 8% of all Nebraska public school students (K-12) have been exposed to some curriculum aspect through the WfS program

“Bancroft-Rosalie Community Schools have used the WfS curriculum in science, math, and other courses to provide our students with an understanding of careers connected to engineering, construction, wind turbine technicians and other possibilities in the wind energy industry. WfS is an effective program for career development. It serves our students and the industry very well.”

*Jon Cerny, Superintendent,
Bancroft-Rosalie Community Schools*



More than 200 undergraduate and 50 graduate students have had direct contact with wind energy curriculum and projects at the University of Nebraska

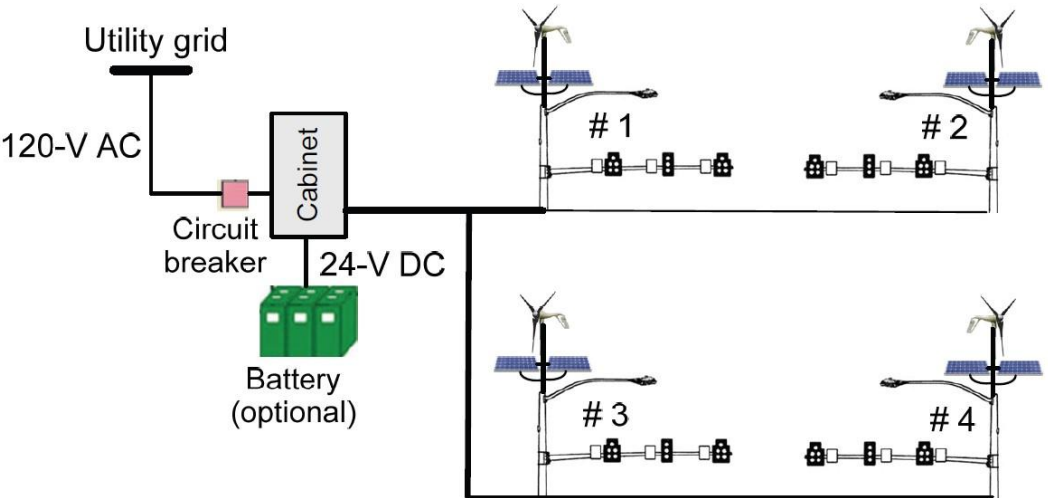
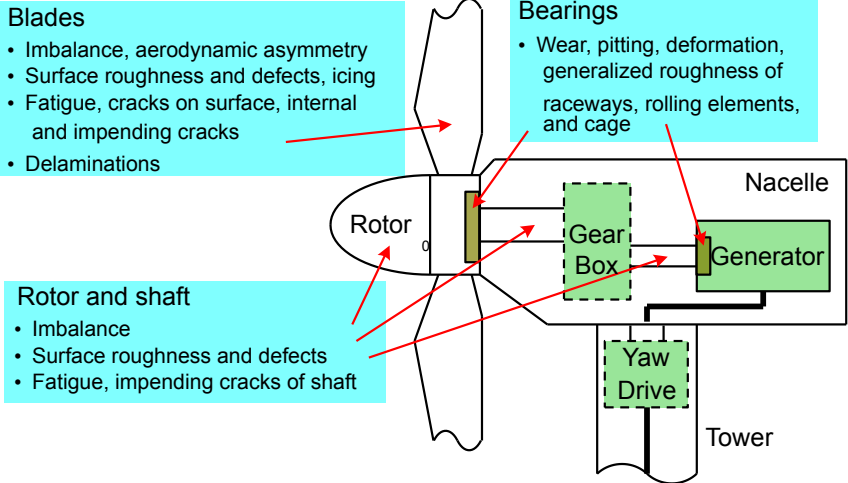

Curriculum Content - Wind Energy Systems in ECE Department

- WIND CHARACTERISTICS, DATA ANALYSIS, AND RESOURCE ESTIMATION
- AERODYNAMICS OF WIND TURBINES
- WIND GENERATORS
 - Induction Machines
 - PM (synchronous) Machines
- POWER CONVERTERS
 - dc/dc converters
 - Inverters
- Control of Wind Turbines
- SITING
 - Environmental Impacts
 - Technical Considerations
- INTEGRATION INTO THE ELECTRIC POWER GRID
- WIND VALUE AND ECONOMICS
 - Avoided Costs
 - Net Metering
 - Renewable Portfolio Standards, RPS (or Renewable Energy Standards, RES)
 - Green Tags
 - Jobs and Economic Development Impact (JEDI) Models
- PUBLIC POLICY ISSUES

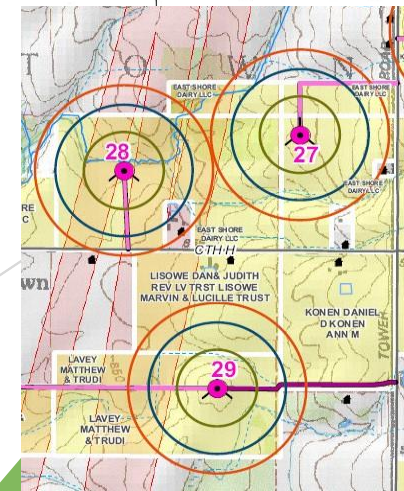
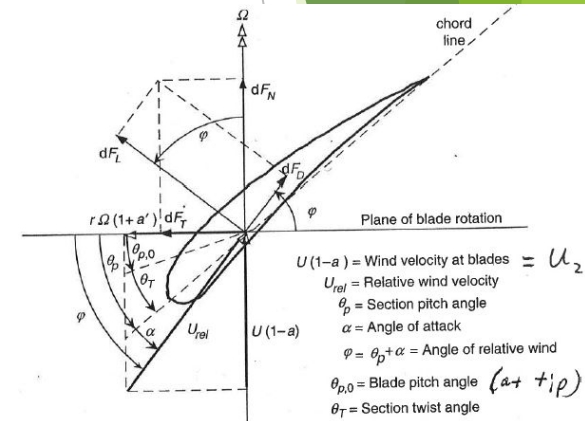
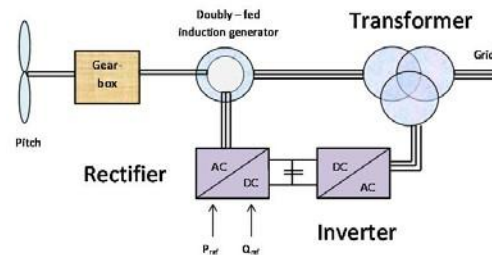
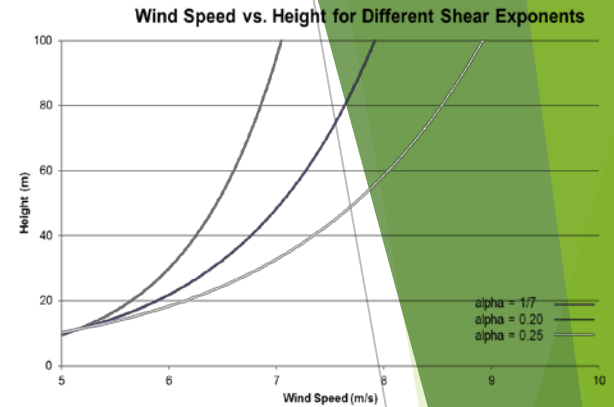

Contact Information

Jerry Hudgins
University of Nebraska
PO Box 880511
Lincoln, NE 68588-0511
402-472-3771

jhudgins2@unl.edu